

POMPE SOMMERGIBILI PER LIQUAMI

SUBMERSIBLE PUMPS FOR SEWAGE WATER

VORTEX 50





VORTEX 75



-  Pompe sommergibili per acque piovane, scarichi di lavatrici e lavastoviglie, fosse biologiche, ecc.
Robusta costruzione. Coperchio, cassa e supporto in ghisa. Girante tipo “vortex” aperta ed arretrata in ghisa. Albero in acciaio inox temperato. Motore a bagno d’olio con protezione termica incorporata. Tenuta meccanica in allumina / grafite. Cavo di alimentazione di 10 metri in neoprene H07RNF per il modello VORTEX 50, in H07RN8-F per il modello VORTEX 75. Protezione IP 68. Isolamento classe F. Temperatura massima del liquido da pompare 40 °C; pH: 6 – 10; massima densità < 1100 kg/m³.

-  Submersible pumps, based on the vortex principle, suitable for the pumping of rain and sewage water.
Heavy duty construction. Pump body, cover and support in cast iron. Back and open impeller “vortex” type in cast iron. Oil bathed motor with built-in motor protector. Shaft in stainless steel. Mechanical seal in alumina/graphite. 10 metres supply cable H07RNF for the model VORTEX 50, H07RN8-F for the model VORTEX 75.
Protection class IP 68. Insulation class F. Max. temperature of pumped liquid 104 °F (40 °C); pH: 6 – 10; max. density < 1100 kg/m³.

-  Pompes submersibles à tourbillon indiquées pour eaux chargées, eaux domestiques, vide-caves, etc.
Construction robuste. Corps de pompe, couvercle et support en fonte. Roue “vortex” semi-ouverte en fonte. Moteur à bain d’huile avec protection thermique. Arbre en acier inox. Garniture mécanique en alumine/graphite. Câble électrique H07RNF de 10 mètres sur le modèle VORTEX 50, H07RN8-F sur le modèle VORTEX 75.
Protection IP 68. Isolation classe F. Température max. du liquide pompé 40 °C; pH: 6 – 10; densité max. < 1100 kg/m³.

-  Abwasser-Tauchpumpen für Schmutzwasser mit Festkörper.
Hergestellt aus hochwertigen und widerstandsfähigen Materialien. Pumpengehäuse und “Vortex” Laufrad aus Grauguß. Antriebswelle aus rostfreiem Stahl. Ölgefüllter Tauchmotor mit thermischen Motorschutz. Gleitringdichtung aus Aluminiumoxyd/Graphit. 10 Meter Kabel H07RNF beim Modell VORTEX 50, 10 Meter Kabel H07RN8-F beim Modell VORTEX 75.
IP 68 Schutz. Isol. Klasse F. Max. Temperatur der Flüssigkeit 40 °C; pH: 6 – 10; max. Dichte < 1100 kg/m³.

Modello Model Modèle Modell	Potenza Power Puissance Pferdestärke		Tensione Voltage Bobinage Spannung V-Hz-ph	A	Prevalenza - Head - Hauteur - Förderhöhe (m)								
	HP	kW			1	2	3	4	5	6	7	8	
	Portata - Capacity - Débit - Fördermenge (l/min)												
VORTEX 50	0,50	0,37	230-50-1	3,0	180	155	129	100	68	37			
VORTEX 75	0,75	0,55	230-50-1	4,2	225	205	188	165	139	105	63	4	

*On request other voltages are available

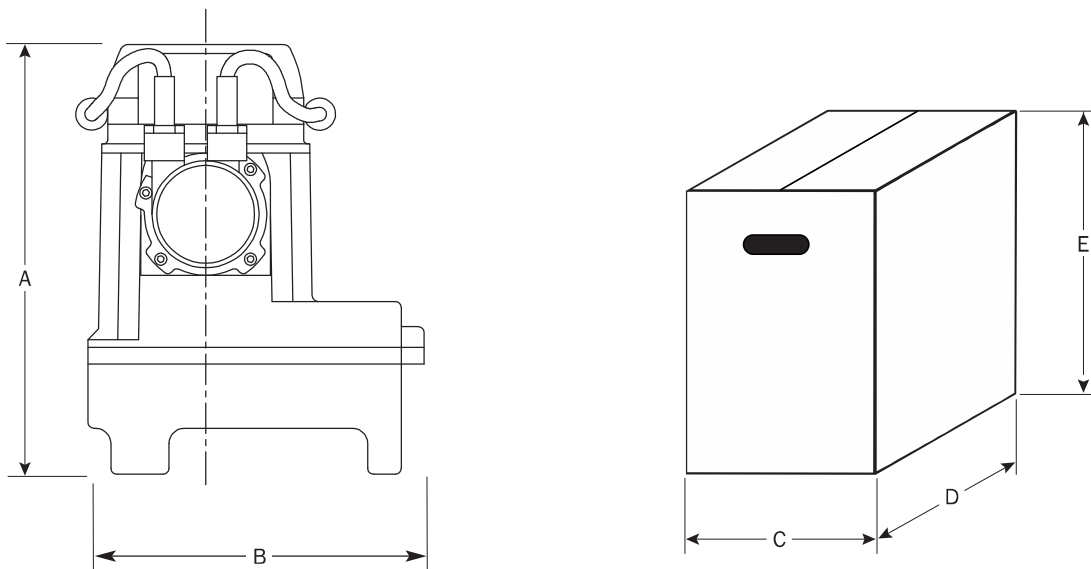
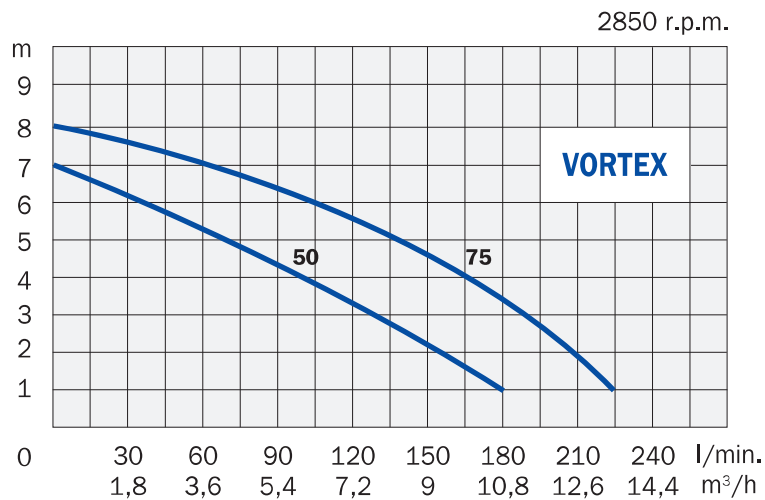

Modello Model Modèle Modell	Mandata Discharge Refoulement Druck-Seite	Corpi solidi Solid parts Corps solides Festkörper mm	Dimensioni - Dimensions - Masstabelle mm					Peso Weight Poids Gewicht kg
			A	B	C	D	E	
			VORTEX 50	1"1/4 - DN 32 horizontal	25	328	141	
VORTEX 75	1"1/4 - DN 32 vertical	30	281	220	230	200	470	17

Modello Model Modèle Modell	Potenza Power Puissance Pferdestärke		Tensione Voltage Bobinage Spannung V-Hz-ph	A	Prevalenza - Head - Hauteur - Förderhöhe (m)								
	HP	kW			1	2	3	4	5	6	7	8	
	Portata - Capacity - Débit - Fördermenge (l/min)												
VORTEX 50	0,50	0,37	230-50-1	3,0	180	155	129	100	68	37			
VORTEX 75	0,75	0,55	230-50-1	4,2	225	205	188	165	139	105	63	4	

*On request other voltages are available

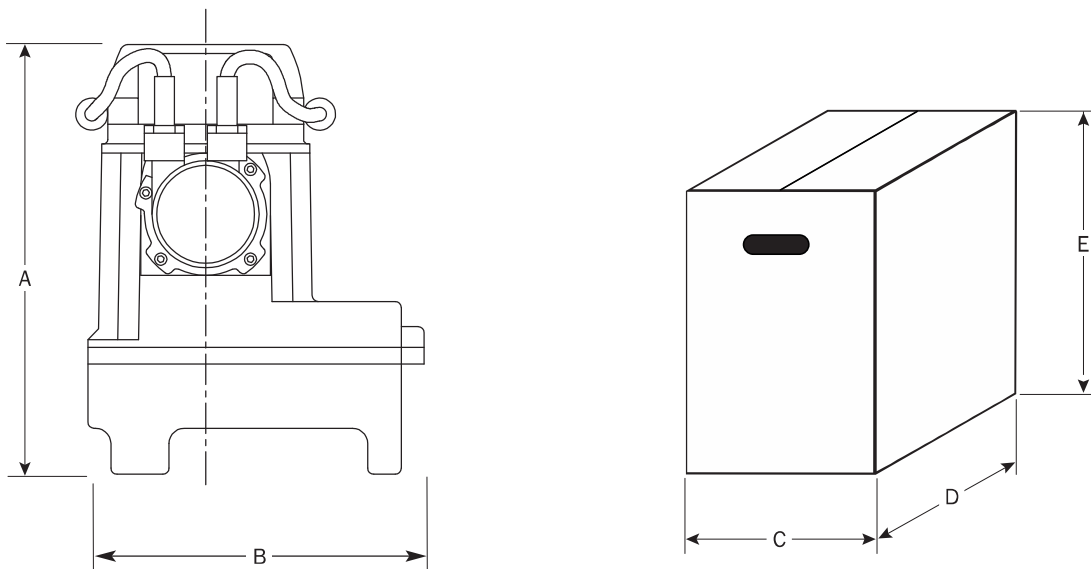
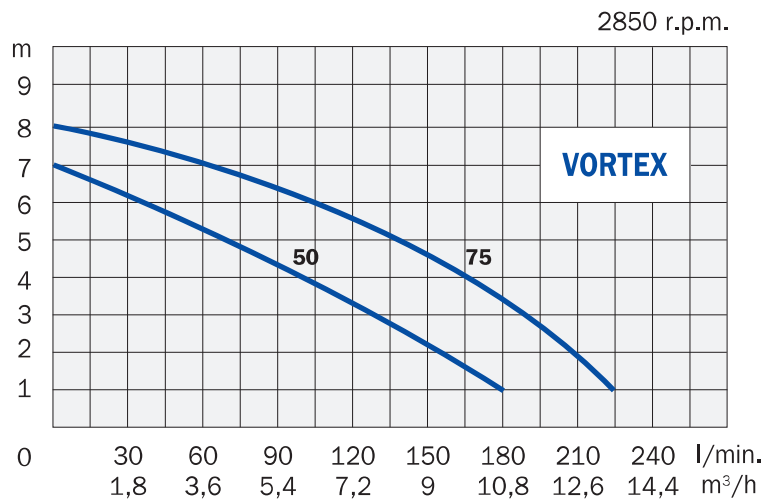

Modello Model Modèle Modell	Mandata Discharge Refoulement Druck-Seite	Corpi solidi Solid parts Corps solides Festkörper mm	Dimensioni - Dimensions - Masstabelle mm					Peso Weight Poids Gewicht kg
			A	B	C	D	E	
			VORTEX 50	1"1/4 - DN 32 horizontal	25	328	141	
VORTEX 75	1"1/4 - DN 32 vertical	30	281	220	230	200	470	17

POMPE SOMMERGIBILI PER LIQUAMI

SUBMERSIBLE PUMPS FOR SEWAGE WATER



VORTEX 100 - 140

-  Pompe sommergibili per liquami ed acque piovane. Robusta costruzione. Coperchio, cassa e supporto in ghisa. Girante aperta ed arretrata in ghisa di tipo “vortex”. Albero in acciaio inox temperato. Motore a bagno d’olio con protezione termica incorporata. Tenuta meccanica in carburo di silicio ed anello di tenuta. Cavo di alimentazione di 10 metri in neoprene H07RN8-F.
Protezione IP 68. Isolamento classe F. Temperatura massima del liquido da pompare 40 °C; pH: 6 – 10; massima densità < 1100 kg/m³.

-  Submersible pumps for sewage and rain water. Heavy duty construction. Pump body, cover and support in cast iron. Back and open impeller “vortex” type in cast iron. Oil bathed motor with built-in motor protector. Shaft in stainless steel. Mechanical seal in silicon carbide and lip seal ring, 10 metres supply cable H07RN8-F.
Protection class IP 68. Insulation class F. Max. temperature of pumped liquid 104 °F (40 °C); pH: 6 – 10; max. density < 1100 kg/m³.

-  Pompes submersibles à tourbillon pour eaux chargées et vide-caves. Construction robuste. Corps de pompe, couvercle et support en fonte. Roue “vortex” semi-ouverte en fonte. Moteur à bain d’huile avec protection thermique. Arbre en acier inox. Garniture mécanique en carbure de silicium et bague d’étanchéité à lèvres. Câble électrique H07RN8-F de 10 mètres.
Protection IP 68. Isolation classe F. Température max. du liquide pompé 40 °C; pH: 6 – 10; densité max. < 1100 kg/m³.

-  Abwasser-Tauchpumpen hergestellt aus hochwertigen und widerstandsfähigen Materialien. Pumpengehäuse und “Vortex” Laufrad aus Grauguß. Antriebswelle aus rostfreiem Stahl. Ölgefüllter Tauchmotor mit thermischen Motorschutz. Gleitringdichtung aus Siliziumkarbid und Öldichtungsring. 10 Meter Kabel H07RN8-F.
IP 68 Schutz. Isol. Klasse F. Max. Temperatur der Flüssigkeit 40 °C; pH: 6 – 10; max. Dichte < 1100 kg/m³.

Modello Model Modèle Modell	Potenza Power Puissance Pferdestärke		Tensione Voltage Bobinage Spannung V-Hz-ph	A	Prevalenza - Head - Hauteur - Förderhöhe (m)								
	HP	kW			1	2	3	4	5	6	7	8	9
	Portata - Capacity - Débit - Fördermenge (l/min)												
VORTEX 100	1,0	0,75	230-50-1	6,2	350	325	298	262	227	188	134	78	
			400-50-3	2,8									
VORTEX 140	1,4	1,04	230-50-1	7,6	450	416	376	340	300	248	190	125	38
			400-50-3	3,0									

*On request other voltages are available

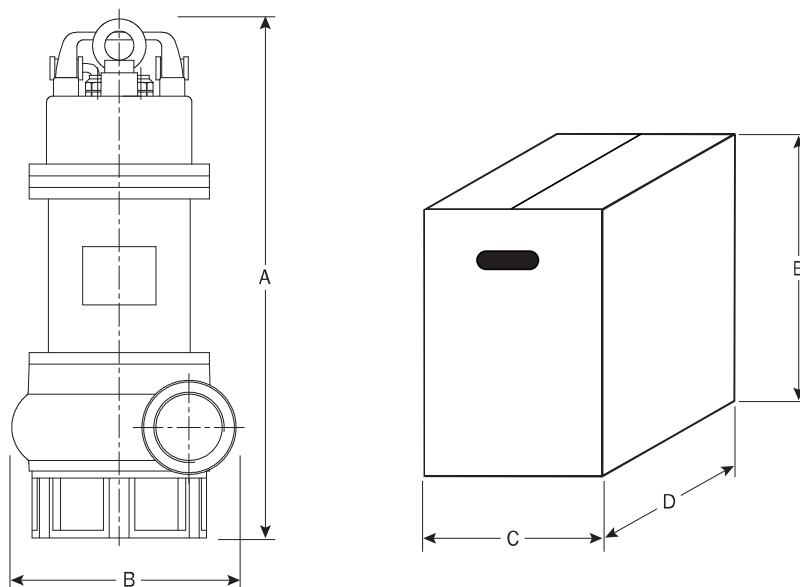
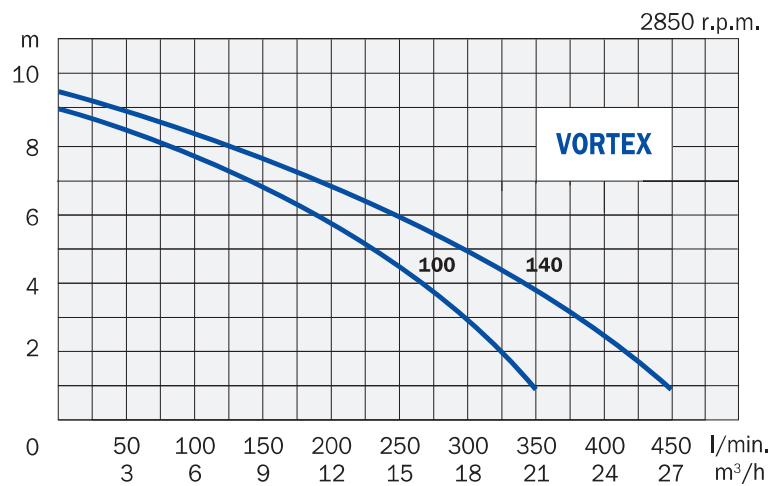

Modello Model Modèle Modell	Mandata Discharge Refoulement Druck-Seite	Corpi solidi Solid parts Corps solides Festkörper	Dimensioni - Dimensions - Masstabelle					Peso Weight Poids Gewicht
			mm					
			A	B	C	D	E	
VORTEX 100	2" - DN 50 horizontal	45	440	194	230	200	470	25
VORTEX 140	2" - DN 50 horizontal	45	440	194	230	200	470	27

POMPE SOMMERGIBILI PER LIQUAMI

SUBMERSIBLE PUMPS FOR SEWAGE WATER

VORTEX 150 - 200



VORTEX 300



PIEDE DI ACCOPIAMENTO
AUTOMATIC COUPLING FOOT



■ ■ Pompe sommergibili adatte alla movimentazione di acque sporche con corpi solidi in sospensione. Particolarmente indicate per acque di scarichi civili, per impianti di depurazione e per uso zootecnico.

Robusta costruzione. Coperchio, cassa statore, corpo di mandata e supporto in ghisa. Girante aperta ed arretrata di tipo "vortex" in ghisa. Albero in acciaio inox temperato. Motore a bagno d'olio. Doppia tenuta meccanica in carburo di silicio in camera d'olio. Cavo di alimentazione di 10 metri in neoprene H07RN8-F. Tensione monofase con condensatore e protezione termica incorporati; tensione trifase con protezione a cura dell'utente.

Protezione IP 68. Isolamento classe F. Temperatura massima del liquido da pompare 40 °C; pH: 6 – 10; massima densità < 1100 kg/m³.

■ ■ Submersible pumps, based on the vortex principle, suitable for the pumping of sewage water with solid parts. Particularly recommended for domestic waste water plants, for industrial water treatment and for a lot of uses in the agriculture and in the zootechnic fields.

Heavy duty construction. Pump housing in cast iron. Back and open impeller "vortex" type in cast iron. Oil bathed motor. Shaft in stainless steel. Double mechanical seal in silicon carbide in oil chamber. 10 metres supply cable H07RN8-F. Single-phase voltage with built-in capacitor and motor protector. The three-phase pump must be protected by a fused remote isolator switch.

Protection class IP 68. Insulation class F. Max. temperature of pumped liquid 104 °F (40 °C); pH: 6 – 10; max. density < 1100 kg/m³.

■ ■ Pompes submersibles à tourbillon indiquées pour eaux chargées avec corps solides. Particulièrement conseillées pour eaux résiduaires, pour vide-caves, pour traitement des eaux industrielles, pour plusieurs emplois dans le domaine agricole et zootechnique. Construction robuste. Couvercle, corps de pompe, corps de refoulement et support en fonte. Roue "vortex" semi-ouverte en fonte. Arbre en acier inox. Moteur à bain d'huile. Double garniture mécanique en carbure de silicium en chambre d'huile. Câble électrique H07RN8-F de 10 mètres. Bobinage monophasé avec condensateur et protection thermique incorporés; bobinage triphasé avec protection par l'utilisateur.

Protection IP 68. Isolation classe F. Température max. du liquide pompé 40 °C; pH: 6 – 10; densité max. < 1100 kg/m³.

■ ■ Abwasser-Tauchpumpen für Schmutzwasser mit Festkörper. Hergestellt aus hochwertigen und widerstandsfähigen Materialien. Pumpengehäuse und "Vortex" Laufrad aus Grauguß. Antriebswelle aus rostfreiem Stahl. Ölgefüllter Tauchmotor. Ölgekühlte Doppel-Gleitringdichtung aus Siliziumcarbid. 10 Meter Kabel H07RN8-F. Einphasenspannung mit Kondensator und thermischen Motorschutz; Dreiphasenspannung, Motorvollschutz nach Benutzersorge.

IP 68 Schutz. Isol. Klasse F. Max. Temperatur der Flüssigkeit 40 °C; pH: 6 – 10; max. Dichte < 1100 kg/m³.

Modello Model Modèle Modell	Potenza Power Puissance Pferdestärke		Tensione Voltage Bobinage Spannung V-Hz-ph	A	Prevalenza - Head - Hauteur - Förderhöhe (m)					
	HP	kW			2	4	6	8	10	12
					Portata - Capacity - Débit - Fördermenge (l/min)					
VORTEX 150	1,5	1,1	230-50-1	9,5	450	350	245	110		
			400-50-3	3,5						
VORTEX 200	2	1,5	230-50-1	10,8	550	480	370	245	100	
			400-50-3	5,0						
VORTEX 300	3	2,2	400-50-3	6,5	700	620	520	390	250	70

*On request other voltages are available

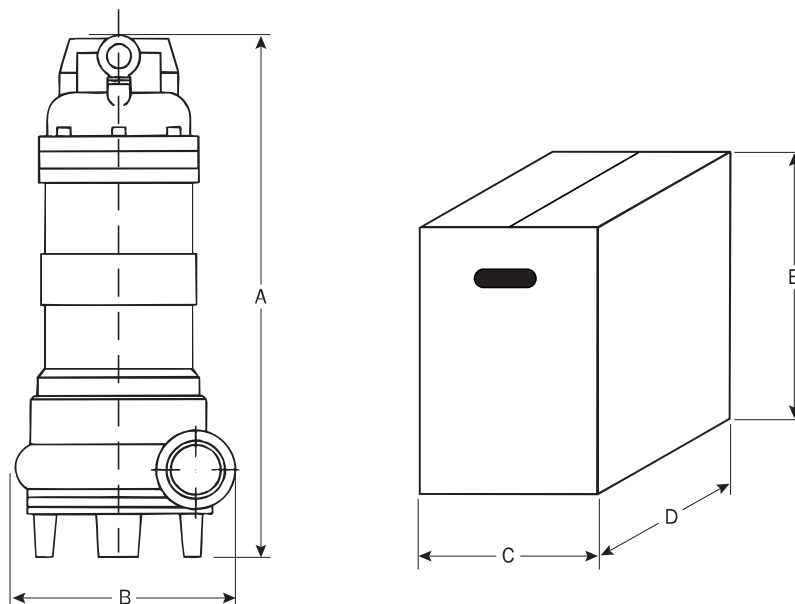
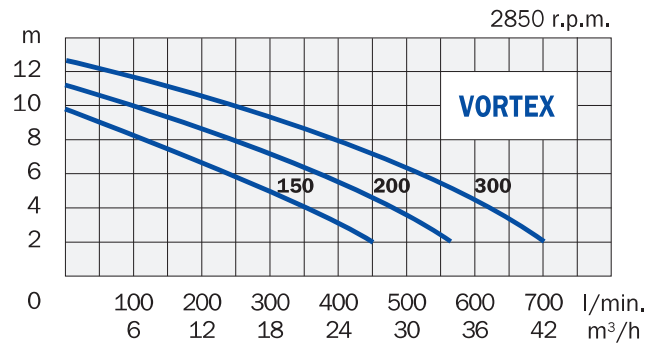

Modello Model Modèle Modell	Mandata Discharge Refoulement Druck-Seite	Corpi solidi Solid parts Corps solides Festkörper	Dimensioni - Dimensions - Masstabelle					Peso Weight Poids Gewicht
			mm					
			A	B	C	D	E	
VORTEX 150	2" - DN 50 horizontal	50	520	220	295	255	550	33
VORTEX 200	2" - DN 50 horizontal	50	520	220	295	255	550	34
VORTEX 300	3" - DN 80 horizontal	55	525	235	295	255	550	39

POMPE SOMMERGIBILI PER LIQUAMI

SUBMERSIBLE PUMPS FOR SEWAGE WATER

VORTEX 400 E





VORTEX 550 E



 Pompe sommergibili adatte alla movimentazione di acque sporche e rifiuti industriali contenenti corpi solidi o filamentosi, di fognature urbane e di liquami di stalla. Robusta costruzione. Coperchio, cassa statore, corpo di mandata e supporto in ghisa. Girante bicanale in ghisa nel modello VORTEX 400 E; girante aperta ed arretrata di tipo “vortex” in ghisa nel modello VORTEX 550 E. Albero in acciaio inox AISI 403. Doppia tenuta meccanica in carburo di silicio in camera d’olio. Cavo di alimentazione di 10 metri in neoprene H07RNF. Protezione a cura dell’utente. IP 68. Isolamento classe F. Temperatura massima del liquido da pompare 40 °C; pH: 6 – 10; massima densità < 1100 kg/m³.

 Submersible pumps suitable for the pumping of sewage effluents containing solid or fibrous parts in industrial, agricultural and domestic waste water plants. Heavy duty construction. Pump housing in cast-iron. Double-channel impeller in cast-iron on the model VORTEX 400 E; back and open impeller “vortex” type in cast-iron on the model VORTEX 550 E. Shaft in stainless steel AISI 403. Double mechanical seal in silicon carbide in oil chamber. 10 metres supply cable H07RNF. The pump must be protected by a fused remote isolator switch. IP 68. Insulation class F. Max. temperature of pumped liquid 104 °F (40 °C); pH: 6 – 10; max. density: < 1100 kg/m³.

 Pompes submersibles indiquées pour eaux chargées avec corps solides. Particulièrement conseillées pour eaux résiduaires, pour traitement des eaux industrielles, pour plusieurs emplois dans le domaine agricole et zootechnique. Construction robuste. Couvercle, corps de pompe, corps de refoulement et support en fonte. Roue bicanal en fonte sur le modèle VORTEX 400 E; roue “vortex” en fonte sur le modèle VORTEX 550 E. Arbre en acier inox AISI 403. Double garniture mécanique en carbure de silicium en chambre d’huile. Câble électrique H07RNF de 10 mètres. Protection par l’usager. Protection IP 68. Isolation classe F. Température max. du liquide pompé 40 °C; pH: 6 – 10; densité max. < 1100 kg/m³.

 Abwasser-Tauchpumpen für Schmutzwasser mit Festkörper. Hergestellt aus hochwertigen und widerstandsfähigen Materialien. Pumpengehäuse und Laufrad aus Grauguß. Antriebswelle aus rostfreiem Stahl AISI 403. Doppelkanallaufwerk beim Modell VORTEX 400 E; “Vortex” Wirbellaufwerk beim Modell VORTEX 550 E. Ölgekühlte Doppel-Gleitringdichtung aus Siliziumkarbid. 10 Meter Kabel H07RNF. Motorvollschutz nach Benutzersorge. IP 68 Schutz. Isol. Klasse F. Max. Temperatur der Flüssigkeit: 40 °C; pH: 6 – 10; max. Dichte < 1100 kg/m³.

Modello Model Modèle Modell	Potenza Power Puissance Pferdestärke		Tensione Voltage Bobinage Spannung V-Hz-ph	A	Prevalenza - Head - Hauteur - Förderhöhe (m)				
	HP	kW			4	8	12	16	20
					Portata - Capacity - Débit - Fördermenge (l/min)				
VORTEX 400 E	4	3	400-50-3	5,0	1000	795	550	272	
VORTEX 550 E	5,5	4	400-50-3	8,2		1020	800	548	245

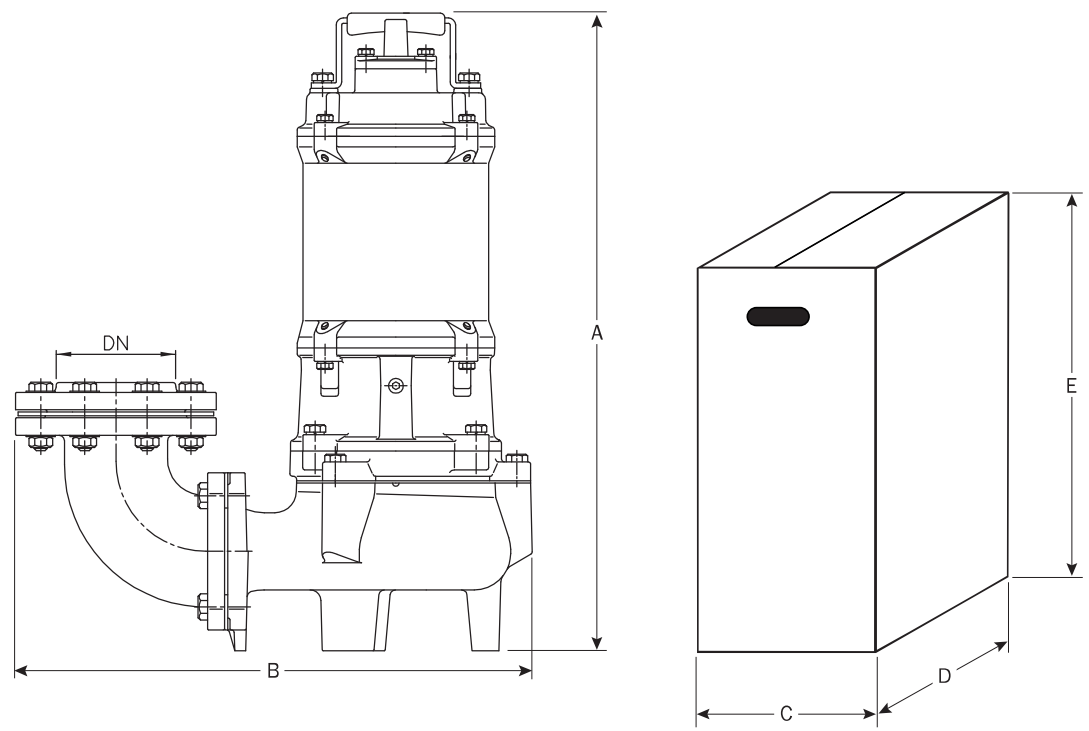
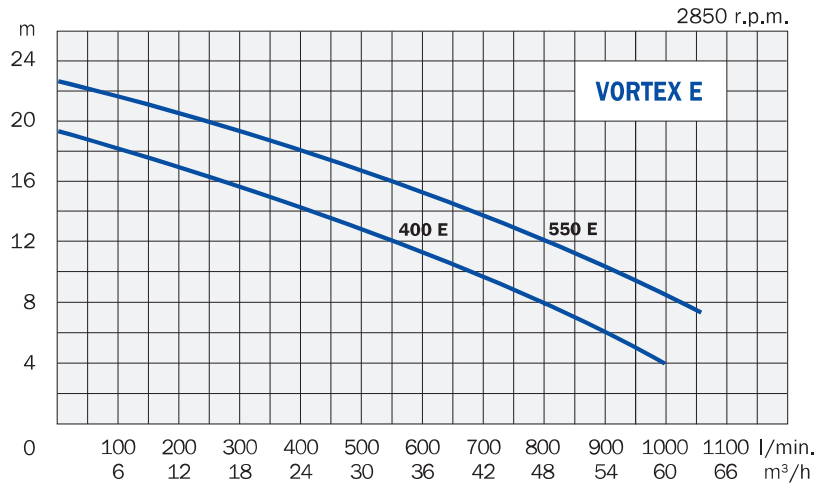

Modello Model Modèle Modell	Mandata Discharge Refoulement Druck-Seite	Corpi solidi Solid parts Corps solides Festkörper	Dimensioni - Dimensions - Masstabelle					Peso Weight Poids Gewicht
			mm					
			A	B	C	D	E	
VORTEX 400 E	3" - DN 80 vertical	35	525	412	290	430	600	42
VORTEX 550 E	3" - DN 80 vertical	56	588	478	400	440	800	58

POMPE SOMMERGIBILI PER LIQUAMI - DN 100

SUBMERSIBLE PUMPS FOR SEWAGE WATER - DN 100

VORTEX 400 - 750





PIEDE DI ACCOPIAMENTO
AUTOMATIC COUPLING FOOT



 Pompe sommergibili adatte alla movimentazione di acque sporche e rifiuti industriali contenenti corpi solidi o filamentosi, fognature urbane e liquami di stalla. Motore 4 poli. Robusta costruzione. Coperchio, cassa statore e corpo mandata in ghisa. Girante monocanale in ghisa. Albero in acciaio inox AISI 420. Doppia tenuta meccanica in camera d'olio: la tenuta inferiore è in carburo di silicio, quella superiore in ceramica/grafite. Cavo di alimentazione di 10 metri in neoprene H07RNF sul modello VORTEX 400, H07RN8-F sui modelli di potenza maggiore. Tensione trifase 400V sul modello VORTEX 400; tensione trifase 400/690V sui modelli di potenza maggiore. Protezione a cura dell'utente. Protezione IP 68. Isolamento classe F. Temperatura massima del liquido da pompare 40 °C; pH: 6 – 10; massima densità 1100 kg/m³.

 Submersible pumps suitable for the pumping of sewage effluents containing solid or fibrous parts in industrial, agricultural and domestic waste water plants, 4 poles motor. Heavy duty construction. Pump housing and impeller in cast-iron. Single channel impeller. Shaft in stainless steel AISI 420. Double mechanical seal in oil chamber: the upper mechanical seal is in ceramic carbon, the lower one is in silicon carbide. 10 metres supply cable H07RNF on model VORTEX 400, H07RN8-F on other models. Three-phase voltage 400V on model VORTEX 400; three-phase voltage 400/690V on the other models. The pumps must be protected by a fused remote isolator switch. Protection class IP 68. Insulation class F. Max. temperature of pumped liquid 104 °F (40 °C); pH: 6 – 10; max. density 1100 kg/m³.

 Pompes submersibles indiquées pour eaux chargées avec corps solides ou fibreux. Particulièrement conseillées pour eaux résiduaires, pour traitement des eaux industrielles et pour d'autres emplois dans le domaine agricole et zootechnique. Moteur 4 pôles. Construction robuste. Couvercle, corps de pompe et corps de refoulement en fonte. Roue monocanal en fonte. Arbre en acier inox AISI 420. Double garniture mécanique en chambre d'huile: la garniture mécanique supérieure est en céramique/graphite, celle inférieure en carbure de silicium. Câble électrique H07RNF de 10 mètres pour le modèle VORTEX 400, H07RN8-F pour les autres modèles. Bobinage triphasé 400 V pour le modèle VORTEX 400; bobinage triphasé 400/690V pour les autres modèles. Protection par l'utilisateur. Protection IP 68. Isolation classe F. Température max. du liquide pompé: 40 °C; pH: 6 – 10; densité max. 1100 kg/m³.

 Abwasser-Tauchpumpen für Schmutzwasser mit Festkörper und Faserstoffen.
Diese Pumpen sind aus hochwertigen Materialien hergestellt. 4 Pol Motor. Pumpengehäuse und Laufrad aus Grauguß. Einkanallaufgrad. Antriebswelle aus rostfreiem Stahl AISI 420. Ölgekühlte Doppel-Gleitringdichtung: Oberdichtung aus Keramik/Graphit, Unterdichtung aus Siliziumkarbid. 10 Meter Kabel H07RNF beim Modell VORTEX 400, H07RN8-F bei allen anderen Modellen. Dreiphasenspannung 400V beim Modell VORTEX 400; Dreiphasenspannung 400/690V bei allen anderen Modellen. Motorvollschutz nach Benutzersorge. IP 68 Schutz. Isol. Klasse F. Max. Temperatur der Flüssigkeit: 40 °C; pH: 6 – 10; max. Dichte: 1100 kg/m³.

Modello Model Modèle Modell	Potenza Power Puissance Pferdestärke		Tensione Voltage Bobinage Spannung V-Hz-ph	A	Prevalenza - Head - Hauteur - Förderhöhe (m)			
	HP	kW			4	8	12	16
					Portata - Capacity - Débit - Fördermenge (l/min)			
VORTEX 400	4	3	400-50-3	7,1	1750	1180	480	
VORTEX 550	5,5	4	400/690-50-3	9,1/5,5	2240	1590	900	190
VORTEX 750	7,5	5,5	400/690-50-3	11,5/7,5	2750	2170	1505	810

*On request other voltages are available

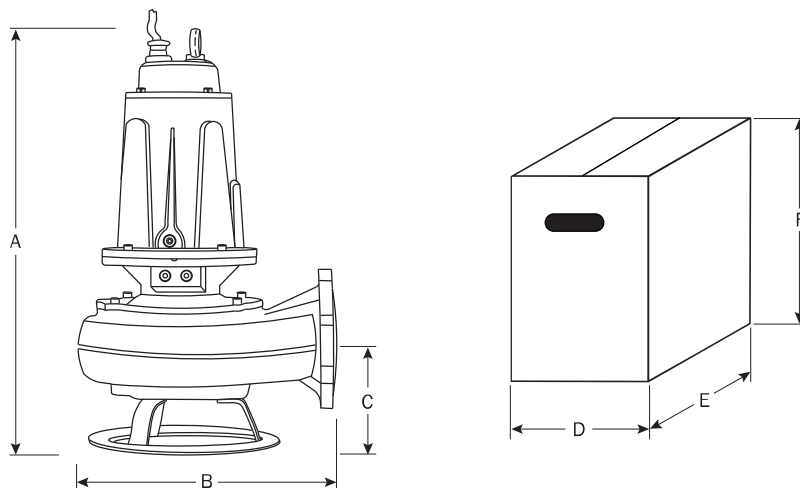
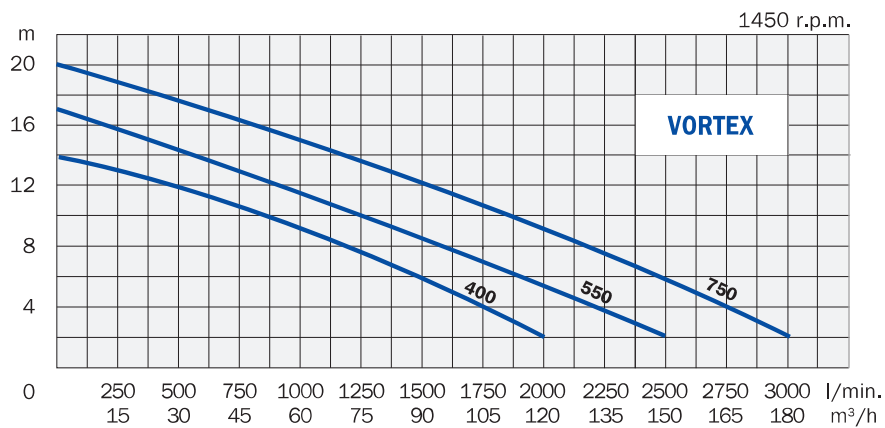

Modello Model Modèle Modell	Mandata Discharge Refoulement Druck-Seite	Corpi solidi Solid parts Corps solides Festkörper mm	Dimensioni - Dimensions - Masstabelle mm						Peso Weight Poids Gewicht kg
			A	B	C	D	E	F	
			VORTEX 400	4" - DN 100 horizontal	85	650	394	163	
VORTEX 550	4" - DN 100 horizontal	90	650	450	212	470	400	620	97
VORTEX 750	4" - DN 100 horizontal	90	650	450	212	470	400	620	103

POMPE SOMMERSIBILI PER LIQUAMI - DN 150

SUBMERSIBLE PUMPS FOR SEWAGE WATER - DN 150

VORTEX 1000 - 6800





PIEDE DI ACCOPPIAMENTO
AUTOMATIC COUPLING FOOT



 Pompe sommergibili adatte alla movimentazione di acque sporche e rifiuti industriali contenenti corpi solidi o filamentosi, fognature urbane e liquami di stalla. Motore 4 poli. Robusta costruzione. Coperchio, cassa statore e corpo mandata in ghisa. Girante monocanale in ghisa. Albero in acciaio inox AISI 420. Doppia tenuta meccanica in camera d'olio: entrambe le tenute sono in carburo di silicio. Cavo di alimentazione di 10 metri in neoprene H07RN8-F tensione trifase 400/690V. Protezione a cura dell'utente. Protezione IP 68. Isolamento classe F. Temperatura massima del liquido da pompare 40 °C; pH: 6 – 10; massima densità 1100 kg/m³.

 Submersible pumps suitable for the pumping of sewage effluents containing solid or fibrous parts in industrial, agricultural and domestic waste water plants, 4 poles motor. Heavy duty construction. Pump housing and impeller in cast-iron. Single channel impeller. Shaft in stainless steel AISI 420. Double mechanical seal in oil chamber: both the mechanical seals are in silicon carbide. 10 metres supply cable H07RN8-F three-phase voltage 400/690V. The pumps must be protected by a fused remote isolator switch. Protection class IP 68. Insulation class F. Max. temperature of pumped liquid 104 °F (40 °C); pH: 6 – 10; max. density 1100 kg/m³.

 Pompes submersibles indiquées pour eaux chargées avec corps solides ou fibreux. Particulièrement conseillées pour eaux résiduaires, pour traitement des eaux industrielles et pour d'autres emplois dans le domaine agricole et zootechnique. Moteur 4 pôles. Construction robuste. Couvercle, corps de pompe et corps de refoulement en fonte. Roue monocanal en fonte. Arbre en acier inox AISI 420. Double garniture mécanique en chambre d'huile: toutes les deux garnitures mécaniques sont en carbure de silicium. Câble électrique H07RN8-F de 10 mètres bobinage triphasé 400/690V. Protection par l'utilisateur. Protection IP 68. Isolation classe F. Température max. du liquide pompé: 40 °C; pH: 6 – 10; densité max. 1100 kg/m³.

 Abwasser-Tauchpumpen für Schmutzwasser mit Festkörper und Faserstoffen. Diese Pumpen sind aus hochwertigen Materialien hergestellt. 4 Pol Motor. Pumpengehäuse und Laufrad aus Grauguß. Einkanallaufgrad. Antriebswelle aus rostfreiem Stahl AISI 420. Ölgekühlte Doppel-Gleitringdichtung: aus Siliziumkarbid. 10 Meter Kabel H07RN8-F Dreiphasenspannung 400/690V. Motorvollschutz nach Benutzersorge. IP 68 Schutz. Isol. Klasse F. Max. Temperatur der Flüssigkeit: 40 °C; pH: 6 – 10; max. Dichte: 1100 kg/m³.

Modello Model Modèle Modell	Potenza Power Puissance Pferdestärke		Tensione Voltage Bobinage Spannung V-Hz-ph	A	Prevalenza - Head - Hauteur - Förderhöhe (m)						
	HP	kW			4	8	12	16	24	32	40
					Portata - Capacity - Débit - Fördermenge (l/min)						
VORTEX 1000	10	7,5	400/690-50-3	15,6/10,0	4500	3320	2150	900			
VORTEX 1500	15	11	400/690-50-3	23,4/14,0	5500	4070	2750	1425			
VORTEX 2000	20	15	400/690-50-3	31,8/18,5	6000	4700	3300	2000			
VORTEX 2700	27	20	400/690-50-3	39,7/22,9	7000	6000	4870	3720	1130		
VORTEX 3400	34	25	400/690-50-3	47,7/27,6	7200		6010	4950	2630		
VORTEX 4000	40	35	400/690-50-3	59,0/34,1	8500		7500	6350	4200	1900	
VORTEX 5500	55	40	400/690-50-3	73,1/42,2	8700		7750	5750	3750	1730	
VORTEX 6800	68	51	400/690-50-3	98,6/56,9	7700		5630	3380			

*On request other voltages are available

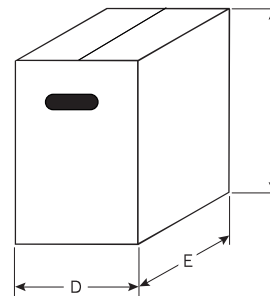
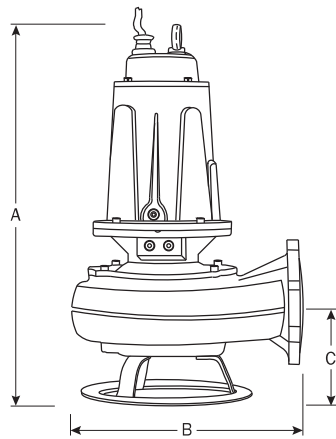
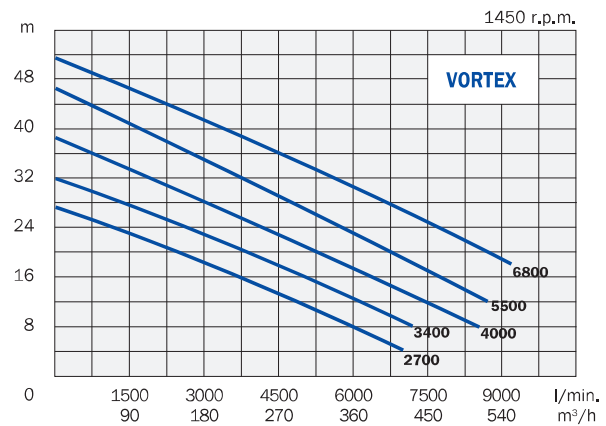
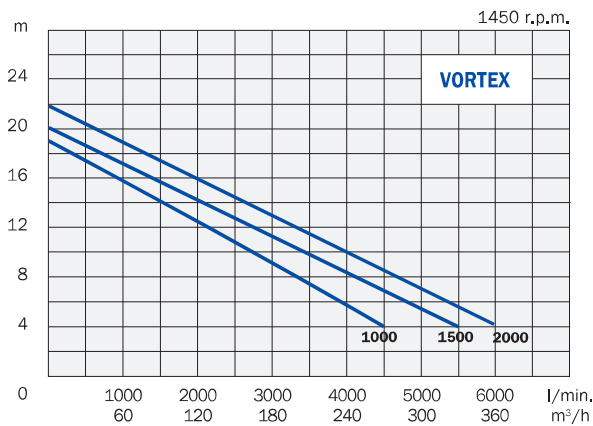

Modello Model Modèle Modell	Mandata Discharge Refoulement Druck-Seite	Corpi solidi Solid parts Corps solides Festkörper	Dimensioni - Dimensions - Masstabelle						Peso Weight Poids Gewicht
			mm						
			A	B	C	D	E	F	
VORTEX 1000	6" - DN 150 horizontal	100	720	528	267	540	430	640	122
VORTEX 1500	6" - DN 150 horizontal	110	956	641	325	670	570	950	260
VORTEX 2000	6" - DN 150 horizontal	110	956	641	325	670	570	950	272
VORTEX 2700	6" - DN 150 horizontal	120	997	641	325	670	570	950	308
VORTEX 3400	6" - DN 150 horizontal	120	997	641	325	670	570	950	320
VORTEX 4000	6" - DN 150 horizontal	120	1190	850	345	980	730	1310	550
VORTEX 5500	6" - DN 150 horizontal	120	1190	850	345	980	730	1310	585
VORTEX 6800	6" - DN 150 horizontal	130	1190	850	345	980	730	1310	600

POMPE CON TRITURATORE

GRINDER PUMPS



Per usi domestici / For domestic uses

Per usi professionali / For professional uses

GRINDER 100: Pompa adatta all'uso domestico. Corpo pompa e girante in ghisa. Dispositivo tritratore in acciaio inox temperato. Doppia tenuta meccanica in camera d'olio: quella inferiore in carburo di silicio, quella superiore in ceramica. Termica a riarmo manuale all'estremità del cavo di alimentazione di 10 metri in neoprene H07RNF. Albero in acciaio inox AISI 420. Isolamento classe F. Protezione IP68. Temperatura massima del liquido da pompare: 40 °C; pH: 6 – 10.

GRINDER 200 - 300 - 500: Questi modelli sono altamente professionali ed affidabili. Indicati per servizi igienici pubblici, alberghi, campeggi, ristoranti, ospedali, ecc. Sono in grado di tritare facilmente pannolini, tovaglioli, pezzi di stoffa, cordicelle, guanti ed oggetti di plastica, gomma, lattice, ecc. Robusta struttura in ghisa. Doppia tenuta meccanica in carburo di silicio in camera d'olio. Dispositivo tritratore in acciaio inox temperato. Albero in acciaio inox AISI 420. Motoprotettore termoamperometrico a riarmo automatico. Cavo di alimentazione di 10 metri in neoprene H07RNF. Isolamento classe F. Protezione IP68. Temperatura massima del liquido da pompare: 40 °C; pH: 6 – 10.

GRINDER 100: Pump suitable for the domestic use. Pump body and impeller in cast iron. Cutting system in tempered stainless steel. Double mechanical seal in oil chamber: the lower one in silicon carbide, the upper one in ceramic. Motor protector with manual reset on the 10 metres supply cable. Shaft in stainless steel AISI 420. Insulation class F. Protection IP68. Max. temperature of pumped liquid: 104 °F (40 °C); pH: 6 – 10.

GRINDER 200 - 300 - 500: These models are very professional and reliable. Suitable for hotels, restaurants, camping, hospitals, etc. These models can chop up easily sanitary towels, napkins, little ropes, gloves and objects in plastic, rubber, latex, etc. Heavy duty structure in cast iron.

Double mechanical seal in silicon carbide in oil chamber. Cutting system in tempered stainless steel. Shaft in stainless steel AISI 420. Built-in motor protector with automatic reset. 10 metres supply cable H07RNF. Insulation class F. Protection IP68. Max. temperature of pumped liquid: 104 °F (40 °C); pH: 6 – 10.

GRINDER 100: Pompe conseillée pour la maison. Corps de pompe et roue en fonte. Broyeur en acier inox trempé. Double garniture mécanique en chambre d'huile: celle inférieure en carbure de silicium, celle supérieure en céramique. Protection du moteur avec réarmement manuel dans une boîte sur le câble électrique de 10 mètres. Arbre moteur en acier inox AISI 420. Isolation classe F. Protection IP 68. Température max. du liquide pompé: 40 °C; pH: 6 – 10.

GRINDER 200 - 300 - 500: Pompes de haute qualité pour hôtels, restaurants, hôpitaux, etc. Elles peuvent triturer serviettes hygiéniques, ficelles, objets en plastique, en gomme, en latex, etc. Construction robuste en fonte. Double garniture mécanique en carbure de silicium en chambre d'huile. Broyeur en acier inox trempé. Arbre en acier inox AISI 420. Protection thermique et ampérométrique avec réarmement automatique. Câble électrique H07RNF de 10 mètres. Isolation classe F. Protection IP 68. Température max. du liquide pompé: 40 °C; pH: 6 – 10.

GRINDER 100: Dieses Modell wird nur für den Einsatz im Haushalt empfohlen. Pumpengehäuse und Laufrad aus Grauguß. Hackwerk aus rostfreiem Stahl. Ölgekühlte Doppel-Gleitringdichtung: Unterdichtung aus Siliziumkarbid, Oberdichtung aus Keramik. Schutzvorrichtung mit manueller Rückstellung im 10 Meter Netzkabel. Antriebswelle aus rostfreiem Stahl AISI 420. Isol. Klasse F. IP 68 Schutz. Max. Temperatur der Flüssigkeit: 40 °C; pH: 6 – 10.

GRINDER 200 - 300 - 500: Diese Modellen sind ausgesprochen professionell und zuverlässig. Geeignet für den Einsatz in der öffentlichen Hygiene, in Hotels, auf Campingplätzen, in Restaurants, Krankenhäusern usw. Sie sind in der Lage, ohne Probleme Windeln, Servietten, Stoffstücke, Kordeln, Handschuhe und Gegenstände aus Gummi, Kunststoff, Latex usw. zu zerhacken. Robuste Struktur aus Grauguß. Ölgekühlte Doppel-Gleitringdichtung aus Siliziumkarbid. Hackwerk aus rostfreiem Stahl. Antriebswelle aus rostfreiem Stahl AISI 420. Motor mit thermischem Motorschutz mit automatischer Rückstellung. 10 Meter Kabel H07RNF. Isol. Klasse F. IP 68 Schutz. Max. Temperatur der Flüssigkeit: 40 °C; pH: 6 – 10.

Modello Model Modèle Modell	Potenza Power Puissance Pferdestärke		Tensione Voltage Bobinage Spannung V-Hz-ph	A	Prevalenza - Head - Hauteur - Förderhöhe (m)								
	HP	kW			4	8	12	16	20	24	28		
					Portata - Capacity - Débit - Fördermenge (l/min)								
GRINDER 100	1	0,75	230-50-1	6,1	159	130	88	30					
GRINDER 200	2	1,5	230-50-1	10,2	136	127	115	100	80	46			
			400-50-3	3,5									
GRINDER 300	3	2,2	400-50-3	5,0	156	150	142	130	119	100	71		
GRINDER 500	5	3,7	400-50-3	8,2		320	287	260	219	163	100		

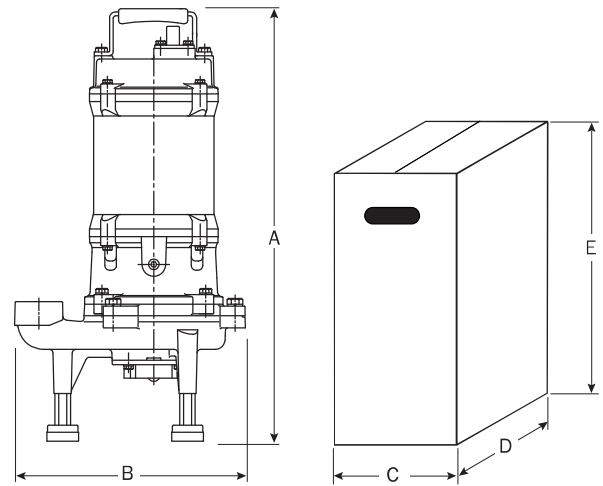
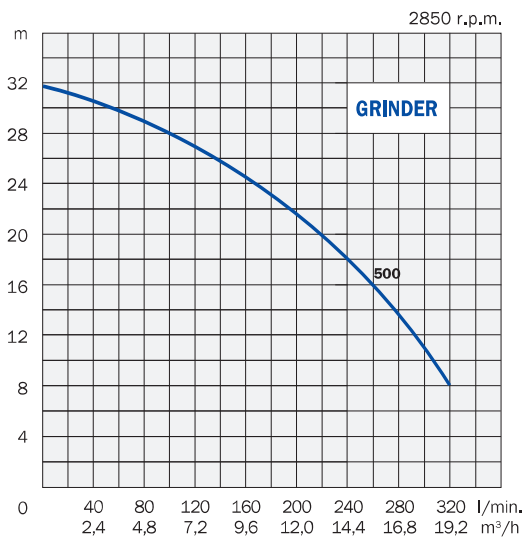
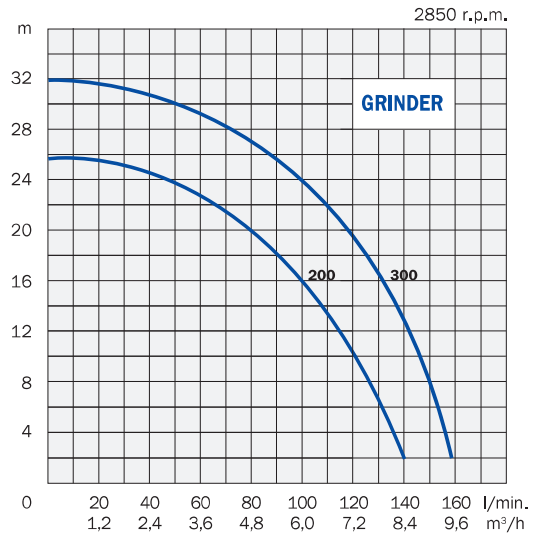
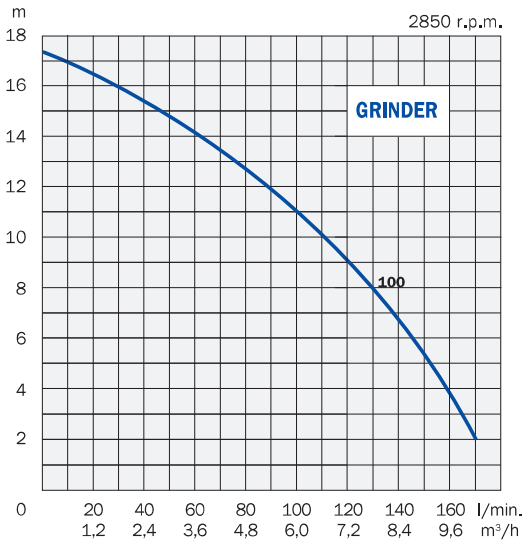

Modello Model Modèle Modell	Mandata Discharge Refoulement Druck-Seite	Dimensioni - Dimensions - Masstabelle					Peso Weight Poids Gewicht kg
		mm					
		A	B	C	D	E	
GRINDER 100	2" - DN 50 vertical	460	290	295	255	490	27
GRINDER 200 1ph	1"1/4 - DN 32 vertical	597	285	270	250	680	36
GRINDER 200 3ph	1"1/4 - DN 32 vertical	546	285	270	250	520	33
GRINDER 300	1"1/4 - DN 32 vertical	546	285	270	250	520	35
GRINDER 500	2" - DN 50 vertical	616	393	500	290	660	53

POMPE SOMMERGIBILI AISI 304

SUBMERSIBLE PUMPS AISI 304

VORTEX SS 304



DRAIN SS 304



 Le **VORTEX SS 304** sono pompe sommergibili con girante arretrata di tipo “vortex” adatte per fosse biologiche, per scarichi di lavatrici, di lavastoviglie, ecc.

Le **DRAIN SS 304** sono pompe sommergibili con girante multicanale per il drenaggio di acque piovane o leggermente sabbiose.

Cassa statore, corpo pompa e girante in acciaio inossidabile AISI 304. Doppia tenuta meccanica in carburo di silicio a bagno d’olio. Albero motore in acciaio inox. Tensione monofase con condensatore e protezione termica incorporati; tensione trifase con protezione a cura dell’utente. Cavo di alimentazione di 10 metri. Protezione IP 68. Isolamento classe F. Temperatura massima dell’acqua: 40 °C; pH: 6 – 13; massima densità 1000 kg/m³.

 **VORTEX SS 304** are submersible pumps with back open impeller “vortex” type suitable for the pumping of sewage water with solid parts.

DRAIN SS 304 are submersible pumps with multichannel impeller suitable to remove clean water or slightly sandy water. Motor case, pump body and impeller in stainless steel AISI 304. Double mechanical seal in silicon carbide in oil chamber. Motor shaft in stainless steel. Single-phase voltage with built-in capacitor and motor protector. The three-phase pump must be protected by a fused remote isolator switch. 10 metres supply cable. Protection class IP 68. Insulation class F. Max water temperature: 104 °F (40 °C); pH: 6 – 13; max. density 1000 kg/m³.

 **VORTEX SS 304** sont des pompes submersibles avec roue “vortex” pour eaux chargées, vide-caves, etc.

DRAIN SS 304 sont des pompes submersibles avec roue multicanal pour le drainage d’eau météorique ou d’eau en peu sablonneuse.

Coquille-stator, corps de pompe et roue en acier inox AISI 304. Double garniture mécanique en carbure de silicium à bain d’huile. Arbre moteur en acier inox. Bobinage monophasé avec condensateur et protection thermique incorporés; bobinage triphasé avec protection par l’usager. Câble électrique de 10 mètres. Protection IP 68. Isolation classe F. Température max de l’eau: 40 °C; pH: 6 – 13; densité max 1000 kg/m³.

 **VORTEX SS 304:** Tauchpumpen mit “Vortex” Laufrad für Sickergruben, für Abflüsse von Waschmaschinen, Geschirrspülmaschinen usw.

DRAIN SS 304: Tauchpumpen mit Multikanallaudfrad zum Abpumpen von Regenwasser oder Wasser mit geringem Sandgehalt.

Statorgehäuse, Pumpengehäuse und Laufrad aus rostfreiem Stahl AISI 304. Ölgekühlte Doppel-Gleitringdichtung aus Siliziumkarbid. Antriebswelle aus rostfreiem Stahl. 10 Meter Kabel H07RNF. Einphasenspannung mit Kondensator und thermischen Motorschutz; Dreiphasenspannung, Motorvollschutz nach Benutzersorge. Isol. Klasse F. IP 68 Schutz. Max Temperatur der Flüssigkeit: 40 °C; pH: 6 – 13; Max Dichte: 1000 kg/m³.

Modello Model Modèle Modell	Potenza Power Puissance Pferdestärke		Tensione Voltage Bobinaje Spannung	A	Prevalenza - Head - Hauteur - Förderhöhe (m)								
	HP	kW			Portata - Capacity - Débit - Fördermenge (l/min)								
					0	2	4	6	8	10	12		
VORTEX 75 SS 304	0,75	0,55	230-50-1	4,2	245	220	170	103	20				
VORTEX 100 SS 304	1	0,75	230-50-1	5,9	285	265	218	160	90	6			
VORTEX 150 SS 304	1,5	1,1	230-50-1	7,0	400	380	338	280	205	127	36		
			400-50-3	2,5									
VORTEX 200 SS 304	2	1,5	230-50-1	9,5	505	502	468	393	300	209	105		
			400-50-3	3,5									
DRAIN 75 SS 304	0,75	0,55	230-50-1	3,2	225	203	166	128	82	31			
DRAIN 100 SS 304	1	0,75	230-50-1	5,9	360	331	285	230	165	92	10		
DRAIN 150 SS 304	1,5	1,1	230-50-1	7,0	450	440	373	300	223	140	52		
			400-50-3	2,5									

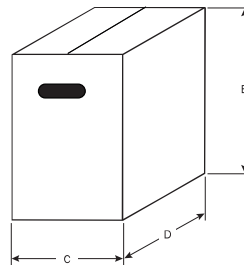
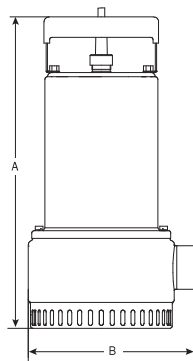
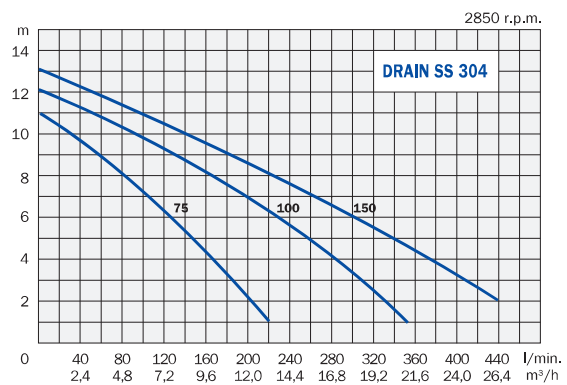
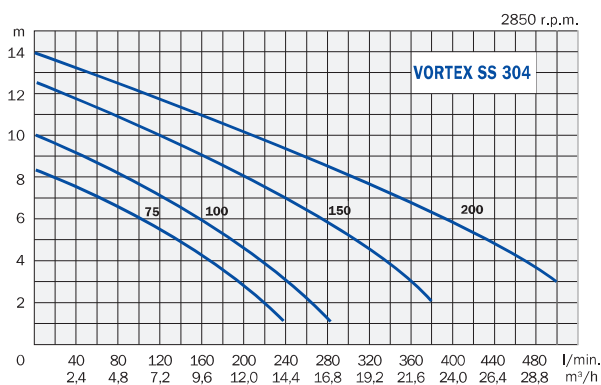

Modello Model Modèle Modell	Mandata Discharge Refoulement Druck-Seite	Corpi solidi Solid parts Corps solides Festkörper	Dimensioni - Dimensions - Masstabelle					Peso Weight Poids Gewicht
			mm					
			A	B	C	D	E	
VORTEX 75 SS 304	1"1/2 - DN 40 horizontal	38	370	195	230	200	470	13
VORTEX 100 SS 304	1"1/2 - DN 40 horizontal	38	400	195	230	200	470	14
	2" - DN 50 horizontal			205				
VORTEX 150 SS 304	2" - DN 50 horizontal	38	400	205	230	200	470	15
VORTEX 200 SS 304	2" - DN 50 horizontal	45	465	210	295	255	490	19
DRAIN 75 SS 304	1"1/2 - DN 40 horizontal	5	360	195	230	200	470	12
DRAIN 100 SS 304	1"1/2 - DN 40 horizontal	5	390	195	230	200	470	14
DRAIN 150 SS 304	2" - DN 50 horizontal	5	390	210	230	200	470	15

POMPE SOMMERGIBILI PER LIQUIDI CORROSIVI

CORROSION RESISTANT SUBMERSIBLE PUMPS

ACCIAIO INOSSIDABILE AISI 316
STAINLESS STEEL AISI 316

VORTEX 100 SS 316



VORTEX 200-1000 SS 316



■
■
 Pompe particolarmente indicate per fognature aggressive, industria chimica, farmaceutica, alimentare, galvanica, tessile, conciaria, lavorazione dei metalli, ecc.

Robusta costruzione. Cassa statore, corpo pompa e girante in acciaio inossidabile **AISI 316**. Girante arretrata tipo "vortex" sul modello da 1 HP; girante aperta di tipo bicanale sui modelli da 2 a 10 HP. Doppia tenuta meccanica in carburo di silicio a bagno d'olio. Guarnizioni in Viton. Cavo di alimentazione di 10 metri in neoprene H07RNF.

Protezione IP 68. Isolamento classe F. Temperatura massima dell'acqua: 40 °C, pH: 3 – 14, massima densità < 1100 kg/m³.

■
■
 These pumps are particularly recommended for aggressive sewage effluents, for acid and alkaline solutions in the pharmaceutical, chemical, galvanic, textile, tanning, metal processing and food industries.

Heavy duty construction. Motor case, pump body and impeller are in stainless steel **AISI 316**. Back open impeller "vortex" type on model 0.75kW; open type double-channel impeller on models from 1.5 to 7.5 kW. Silicon carbide double mechanical seal in oil chamber. Viton packing. 10 metres supply cable H07RNF. Protection class IP 68. Insulation class F. Max water temperature: 104 °F (40 °C), pH: 3 – 14, max. density < 1100 kg/m³.

■
■
 Pompes submersibles indiquées pour eaux chargées particulièrement corrosives des industries chimiques, pharmaceutiques, alimentaires, galvaniques, textiles, tanneries, métallurgiques, etc.

Construction robuste. Coquille stator, corps de pompe et roue en acier inox **AISI 316**. Roue "vortex" sur le modèle de 1 CV; roue de type bicanal ouvert sur les modèles de 2 jusqu'à 10 CV. Double garniture mécanique en carbure de silicium en chambre d'huile. Garnitures en Viton. Câble électrique de 10 mètres. Protection IP 68. Isolation class F. Température max. de l'eau: 40 °C, pH: 3 – 14, densité max < 1100 kg/m³.

■
■
 Pumpen, die besonders für aggressive Abwässer, die chemische und die pharmazeutische Industrie, die Lebensmittelindustrie, Galvanisierungsbetriebe, die Textilindustrie, Gerbereien, Metall verarbeiteten Unternehmen usw. geeignet sind.

Hergestellt aus hochwertigen und widerstandsfähigen Materialien. Statorgehäuse, Pumpengehäuse und Laufrad aus rostfreiem Stahl **AISI 316**. Wirbelauftrad beim Modell mit 1 HP; Zweikanallauftrad auf Modellen mit 2 bis zu 10 HP. Ölgekühlte Doppel-Gleitringdichtung aus Siliziumkarbid. Viton-Dichtungen. 10 Meter Kabel H07RNF.

IP 68 Schutz. Isol. klasse F. Max. Temperatur der Flüssigkeit: 40 °C, pH: 3 – 14, Max Dichte: < 1100 kg/m³.